

MANUAL TRANSMISSION

SECTION **MT**

GI

MA

EM

LC

EC

FE

CL

MT

AT

PD

FA

RA

BR

ST

RS

BT

HA

EL

IDX

CONTENTS

PREPARATION	2	Gear Components	11
Special Service Tools	2	Shift Control Components	12
Commercial Service Tool.....	4	DISASSEMBLY	13
NOISE, VIBRATION AND HARSHNESS (NVH)		Case Components	13
TROUBLESHOOTING	5	Shift Control Components	14
NVH Troubleshooting Chart.....	5	Gear Components	14
DESCRIPTION	6	INSPECTION	17
Cross-sectional View	6	Shift Control Components	17
ON-VEHICLE SERVICE	7	Gear Components	17
Replacing Rear Oil Seal.....	7	ASSEMBLY	19
Position Switch Check.....	7	Gear Components	19
REMOVAL AND INSTALLATION	8	Shift Control Components	25
Removal.....	8	Case Components	26
Installation.....	9	SERVICE DATA AND SPECIFICATIONS (SDS)	29
MAJOR OVERHAUL	10	General Specifications.....	29
Case Components	10	Inspection and Adjustment	29

PREPARATION

Special Service Tools

The actual shapes of Kent-Moore tools may differ from these special service tools illustrated here.

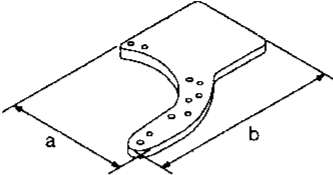
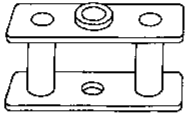
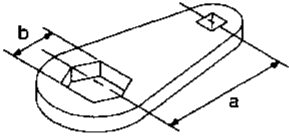
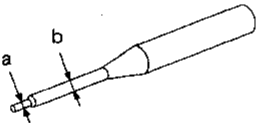
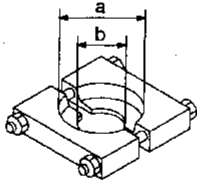
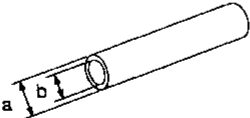
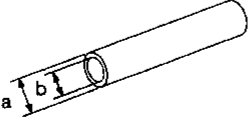
Tool number (Kent-Moore No.) Tool name	Description
ST23810001 (—) Adapter setting plate	<div style="display: flex; justify-content: space-between; align-items: center;"> <div style="text-align: center;">  <p>NT407</p> </div> <div style="text-align: right;"> <p>Fixing adapter plate with gear assembly</p> <p>a: 166 mm (6.54 in) b: 270 mm (10.63 in)</p> </div> </div>
KV31100401 (—) Transmission press stand	<div style="display: flex; justify-content: space-between; align-items: center;"> <div style="text-align: center;">  <p>NT068</p> </div> <div style="text-align: right;"> <p>Pressing counter gear and mainshaft</p> </div> </div>
ST22520000 (J26348) Wrench	<div style="display: flex; justify-content: space-between; align-items: center;"> <div style="text-align: center;">  <p>NT409</p> </div> <div style="text-align: right;"> <p>Tightening mainshaft lock nut</p> <p>a: 100 mm (3.94 in) b: 41 mm (1.61 in)</p> </div> </div>
ST23540000 (J25689-A) Pin punch	<div style="display: flex; justify-content: space-between; align-items: center;"> <div style="text-align: center;">  <p>NT442</p> </div> <div style="text-align: right;"> <p>Removing and installing fork rod retaining pin</p> <p>a: 2.3 mm (0.091 in) dia. b: 4 mm (0.16 in) dia.</p> </div> </div>
ST30031000 (J22912-01) Puller	<div style="display: flex; justify-content: space-between; align-items: center;"> <div style="text-align: center;">  <p>NT411</p> </div> <div style="text-align: right;"> <p>Removing and installing 1st gear bushing Removing main drive gear bearing Measuring wear of baulk rings</p> <p>a: 90 mm (3.54 in) dia. b: 50 mm (1.97 in) dia.</p> </div> </div>
ST23860000 (—) Drift	<div style="display: flex; justify-content: space-between; align-items: center;"> <div style="text-align: center;">  <p>NT065</p> </div> <div style="text-align: right;"> <p>Installing counter drive gear</p> <p>a: 38 mm (1.50 in) dia. b: 33 mm (1.30 in) dia.</p> </div> </div>
ST22360002 (J25679-01) Drift	<div style="display: flex; justify-content: space-between; align-items: center;"> <div style="text-align: center;">  <p>NT065</p> </div> <div style="text-align: right;"> <p>Installing counter gear front and rear end bearings</p> <p>a: 29 mm (1.14 in) dia. b: 23 mm (0.91 in) dia.</p> </div> </div>

PREPARATION

Special Service Tools (Cont'd)

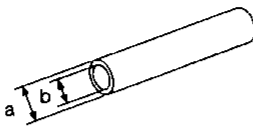
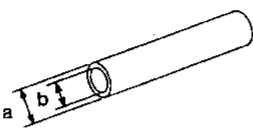
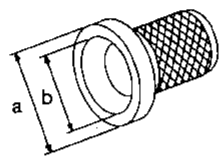
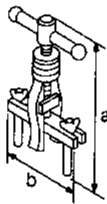
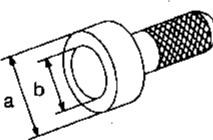
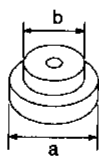
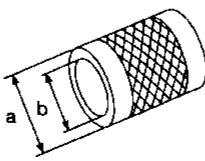
Tool number (Kent-Moore No.) Tool name	Description	
ST22350000 (J25678-01) Drift	Installing OD gear bushing  NT065 a: 34 mm (1.34 in) dia. b: 28 mm (1.10 in) dia.	GI MA EM
ST23800000 (J25691-01) Drift	Installing front cover oil seal  NT065 a: 44 mm (1.73 in) dia. b: 31 mm (1.22 in) dia.	LC EC
ST33400001 (J26082) Drift	Installing rear oil seal  NT086 a: 60 mm (2.36 in) dia. b: 47 mm (1.85 in) dia.	FE CL MT
ST33290001 (J34286) Puller	Removing rear oil seal  NT414 a: 250 mm (9.84 in) b: 160 mm (6.30 in)	AT PD
ST30720000 (—) Drift	Installing mainshaft ball bearing  NT115 a: 77 mm (3.03 in) dia. b: 55.5 mm (2.185 in) dia.	FA RA BR
ST30613000 (J25742-3) Drift	Installing main drive gear bearing  NT073 a: 71.5 mm (2.815 in) dia. b: 47.5 mm (1.870 in) dia.	ST RS
ST33200000 (J26082) Drift	Installing counter rear bearing Installing 3rd & 4th synchronizer assembly  NT091 a: 60 mm (2.36 in) dia. b: 44.5 mm (1.752 in) dia.	BT HA EL

PREPARATION

Special Service Tools (Cont'd)

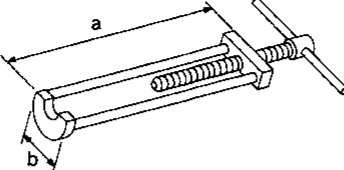
Tool number (Kent-Moore No.) Tool name	Description
KV32101330 (See J26349-A) Puller	 <p data-bbox="1031 287 1421 308">Removing overdrive mainshaft bearing</p> <p data-bbox="1031 436 1242 457">a: 447 mm (17.60 in)</p> <p data-bbox="1031 463 1242 485">b: 100 mm (3.94 in)</p> <p data-bbox="454 468 511 489">NT408</p>

Commercial Service Tool

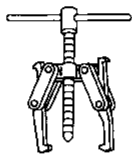
Tool name	Description
Puller	 <p data-bbox="1023 676 1453 734">Removing counter bearings, counter drive and OD gears</p> <p data-bbox="454 861 511 883">NT077</p>

NOISE, VIBRATION AND HARSHNESS (NVH) TROUBLESHOOTING

NVH Troubleshooting Chart

Use the chart below to help you find the cause of the problem. The numbers indicate the order of the inspection. If necessary, repair or replace these parts.

MANUAL TRANSMISSION

		Refer to MA section ("Checking M/T Oil", "CHASSIS AND BODY MAINTENANCE").			MT-10	MT-10	MT-12	MT-12	MT-11	MT-10, 11	MT-11	MT-11
Reference page												
SUSPECTED PARTS (Possible cause)		OIL (Level low)	OIL (Wrong)	OIL (Level too high)	GASKET (Damaged)	OIL SEAL (Worn or damaged)	CHECK PLUG RETURN SPRING AND CHECK BALL (Worn or damaged)	SHIFT FORK (Worn)	GEAR (Worn or damaged)	BEARING (Worn or damaged)	BAULK RING (Worn or damaged)	INSERT SPRING (Damaged)
Symptom	Noise	1	2						3	3		
	Oil leakage		3	1	2	2						
	Hard to shift or will not shift		1	1							2	2
	Jumps out of gear						1	2	2			

GI
 MA
 EM
 LC
 EC
 FE
 CL
MT
 AT
 PD
 FA
 RA
 BR
 ST
 RS
 BT
 HA
 EL
 IDX

DESCRIPTION

Cross-sectional View

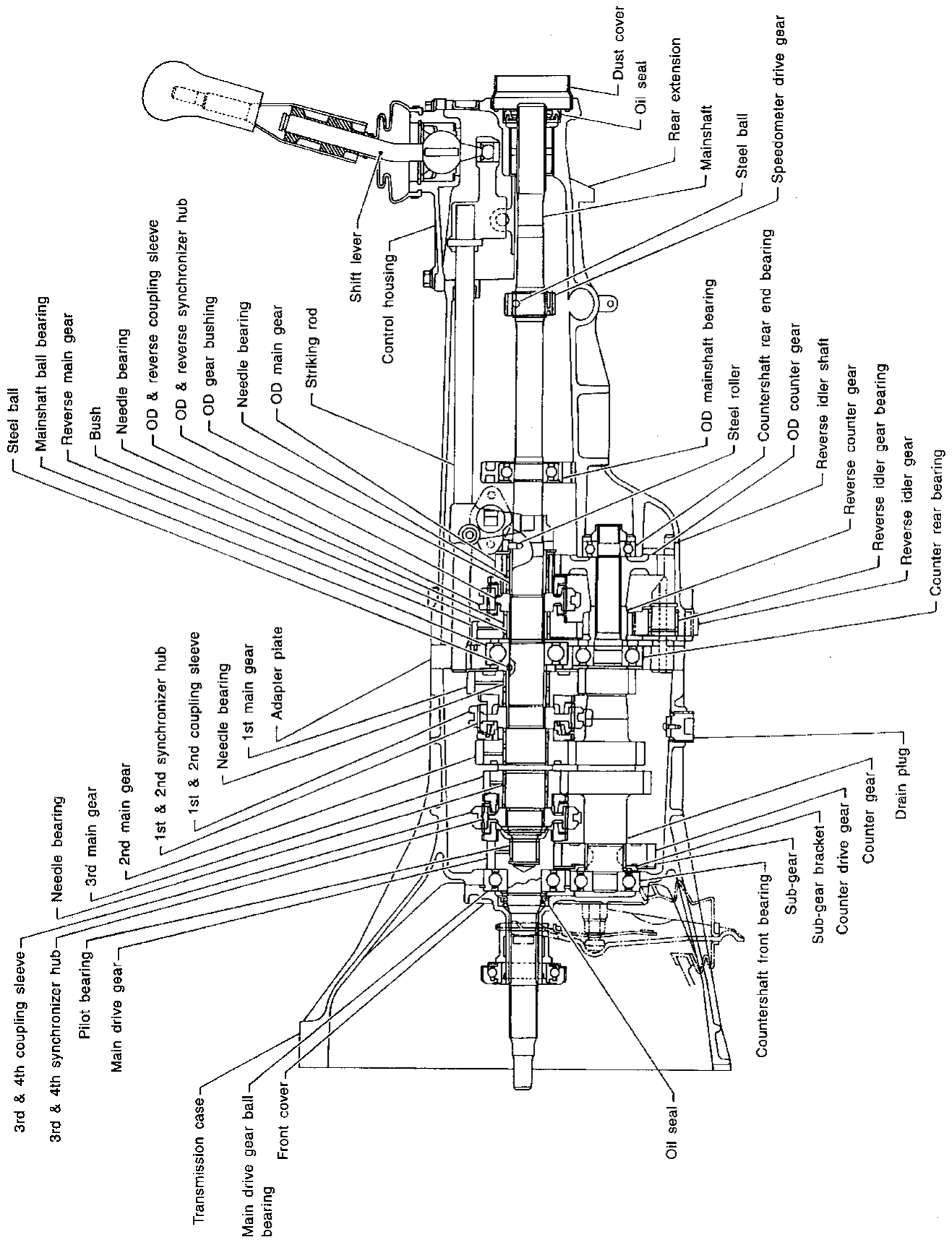

ON-VEHICLE SERVICE

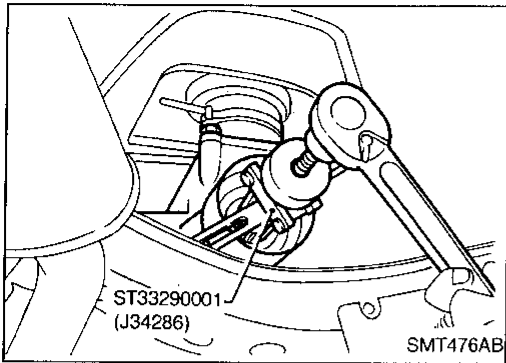

Replacing Rear Oil Seal

REMOVAL

1. Remove propeller shaft. Refer to PD section ("Removal", "PROPELLER SHAFT").
2. Remove rear oil seal.

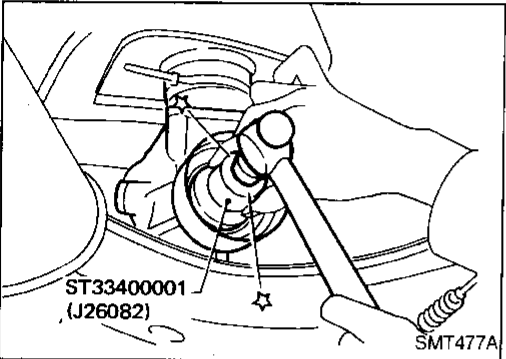

INSTALLATION

1. Install rear oil seal.
2. Install propeller shaft. Refer to PD section ("Installation", "PROPELLER SHAFT").

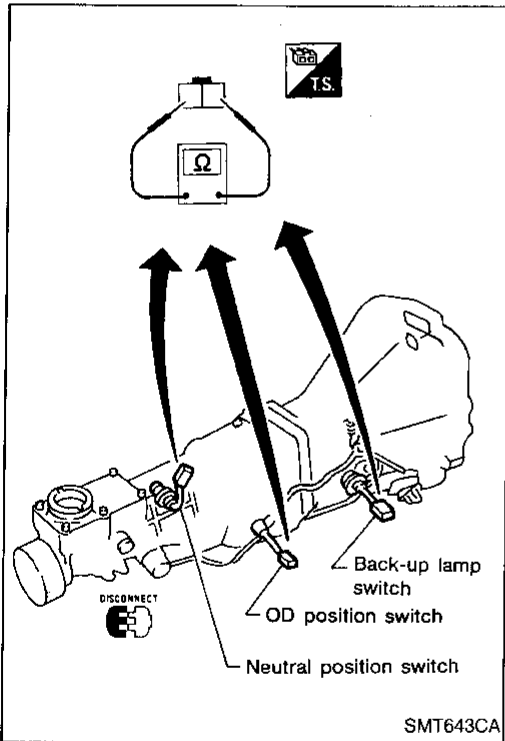

Position Switch Check

Switch	Gear position	Continuity
Back-up lamp switch	Reverse	Yes
	Except reverse	No
Neutral position switch	Neutral	Yes
	Except neutral	No
OD position switch	OD	Yes
	Except OD	No

GI

MA

EM

LC

EC

FE

CL

MT

AT

PD

FA

RA

BR

ST

RS

BT

HA

EL

IDX

REMOVAL AND INSTALLATION

Removal

CAUTION:

When removing the transmission assembly from engine, first remove the crankshaft position sensor (OBD) from the assembly. Be careful not to damage sensor edge and ring gear teeth.

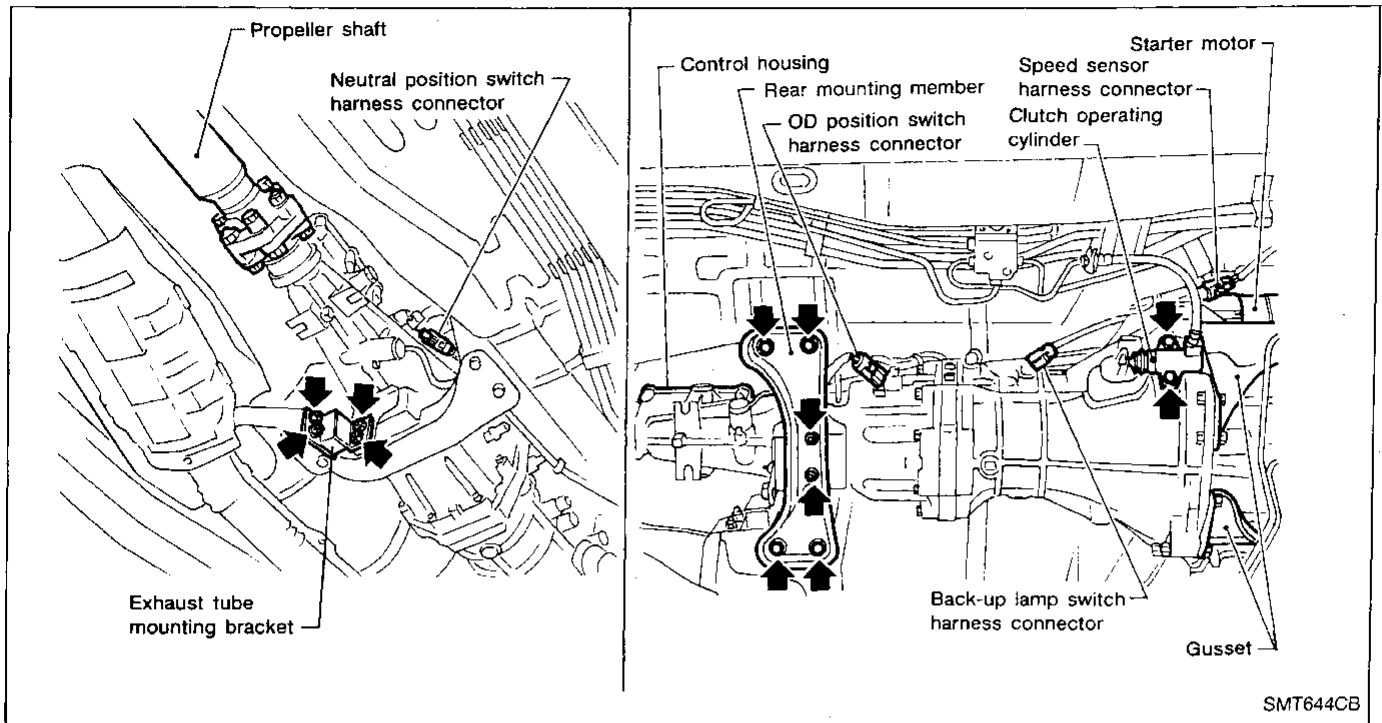

1. Remove battery negative terminal.
2. Remove shift lever with control housing from transmission.
3. Remove crankshaft position sensor (OBD) from upper side of transmission case.
4. Remove clutch operating cylinder from transmission. Tighten clutch operating cylinder to the specified torque. Refer to CL section ("CLUTCH SYSTEM").
5. Disconnect speed sensor, OD position switch, back-up lamp switch, rear heated oxygen sensor and neutral position switch harness connectors.
6. Remove starter motor from transmission.
Ⓜ: 30 - 41 N·m (3.1 - 4.2 kg·m, 22 - 30 ft·lb)
7. Remove propeller shaft. Refer to PD section ("Removal", "PROPELLER SHAFT").
 - Insert plug into rear oil seal after removing propeller shaft.
 - Be careful not to damage spline, sleeve yoke and rear oil seal when removing propeller shaft.
8. Remove gussets from transmission or engine.
9. Remove exhaust tube mounting bracket from transmission. Refer to FE section ("EXHAUST SYSTEM").
10. Support manual transmission with a jack.
11. Remove rear mounting member. Tighten rear mounting member to the specified torque. Refer to EM section ("ENGINE REMOVAL").
12. Lower manual transmission as much as possible.

REMOVAL AND INSTALLATION

Removal (Cont'd)

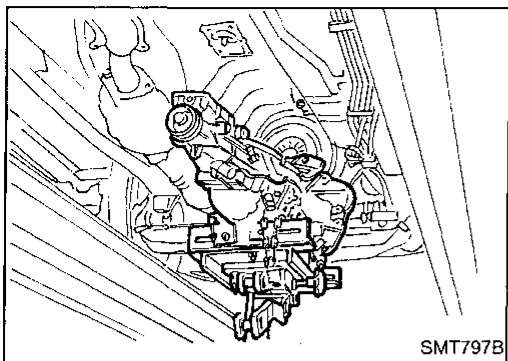

13. Remove transmission fixing bolts.
14. Remove transmission from engine.

- Support manual transmission while removing it.

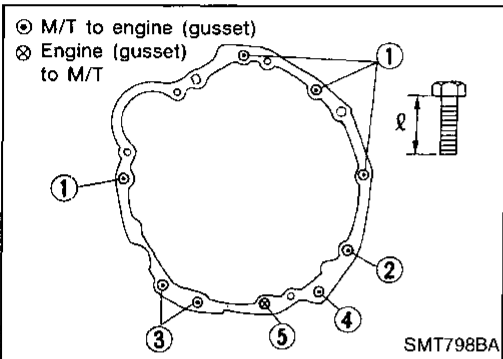

Installation

- Tighten transmission fixing bolts.

Bolt No.	Tightening torque N·m (kg-m, ft-lb)	"l" mm (in)
①	39 - 49 (4.0 - 5.0, 29 - 36)	60 (2.36)
②	39 - 49 (4.0 - 5.0, 29 - 36)	70 (2.76)
③ *	29 - 39 (3.0 - 4.0, 22 - 29)	35 (1.38)
④ *	29 - 39 (3.0 - 4.0, 22 - 29)	65 (2.56)
⑤	29 - 39 (3.0 - 4.0, 22 - 29)	25 (0.98)
Gusset to engine	29 - 39 (3.0 - 4.0, 22 - 29)	20 (0.79)

*: With nut.

- Install any part removed.

GI

MA

EM

LC

EC

FE

CL

MT

AT

PD

FA

RA

BR

ST

RS

BT

HA

EL

IDX

MAJOR OVERHAUL

Case Components

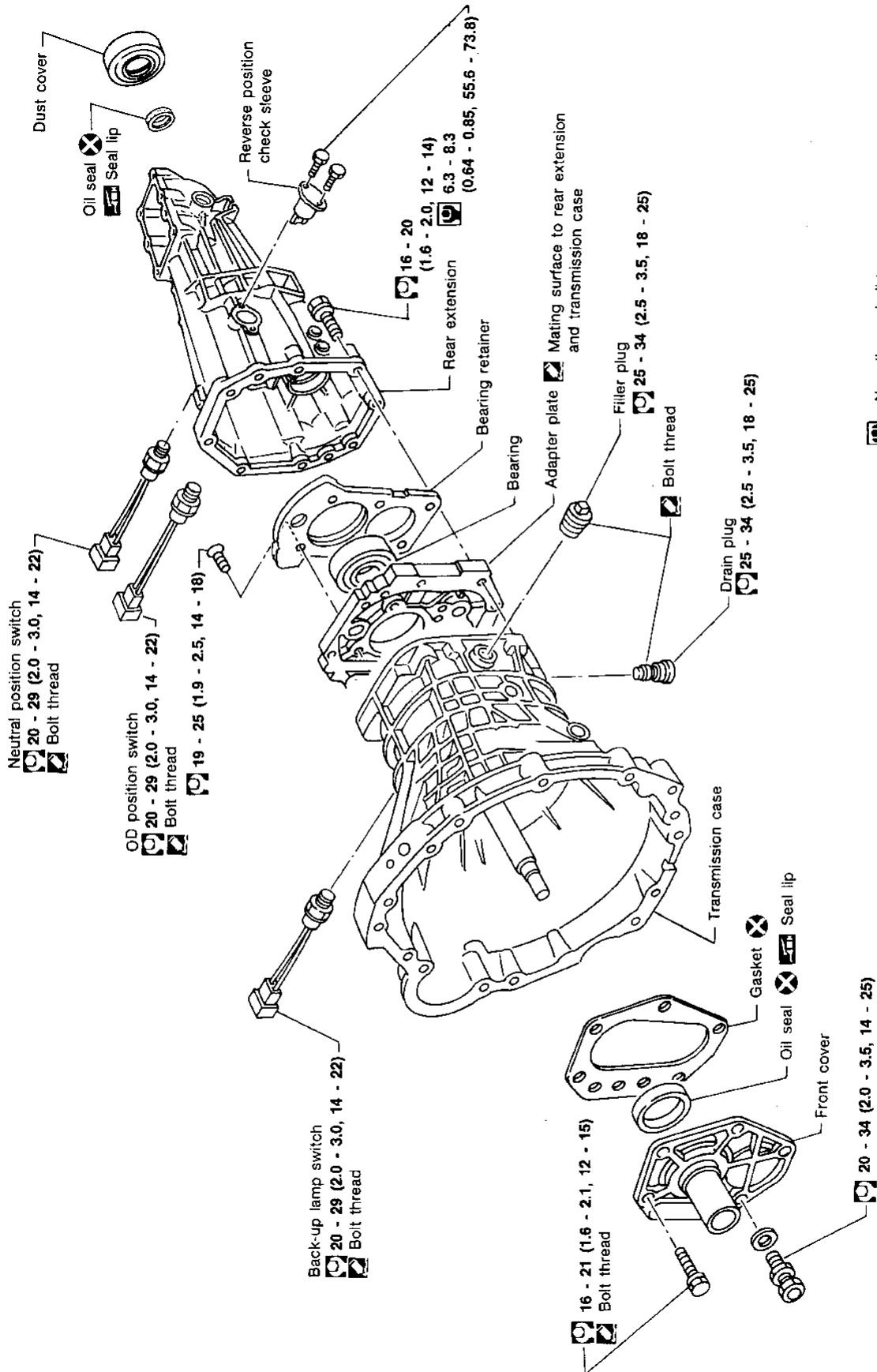

- : N•m (kg-m, in-lb)
- : N•m (kg-m, ft-lb)
- : Apply recommended sealant (Nissan genuine part: KP610-00250) or equivalent.

MAJOR OVERHAUL

Gear Components

SEC. 322

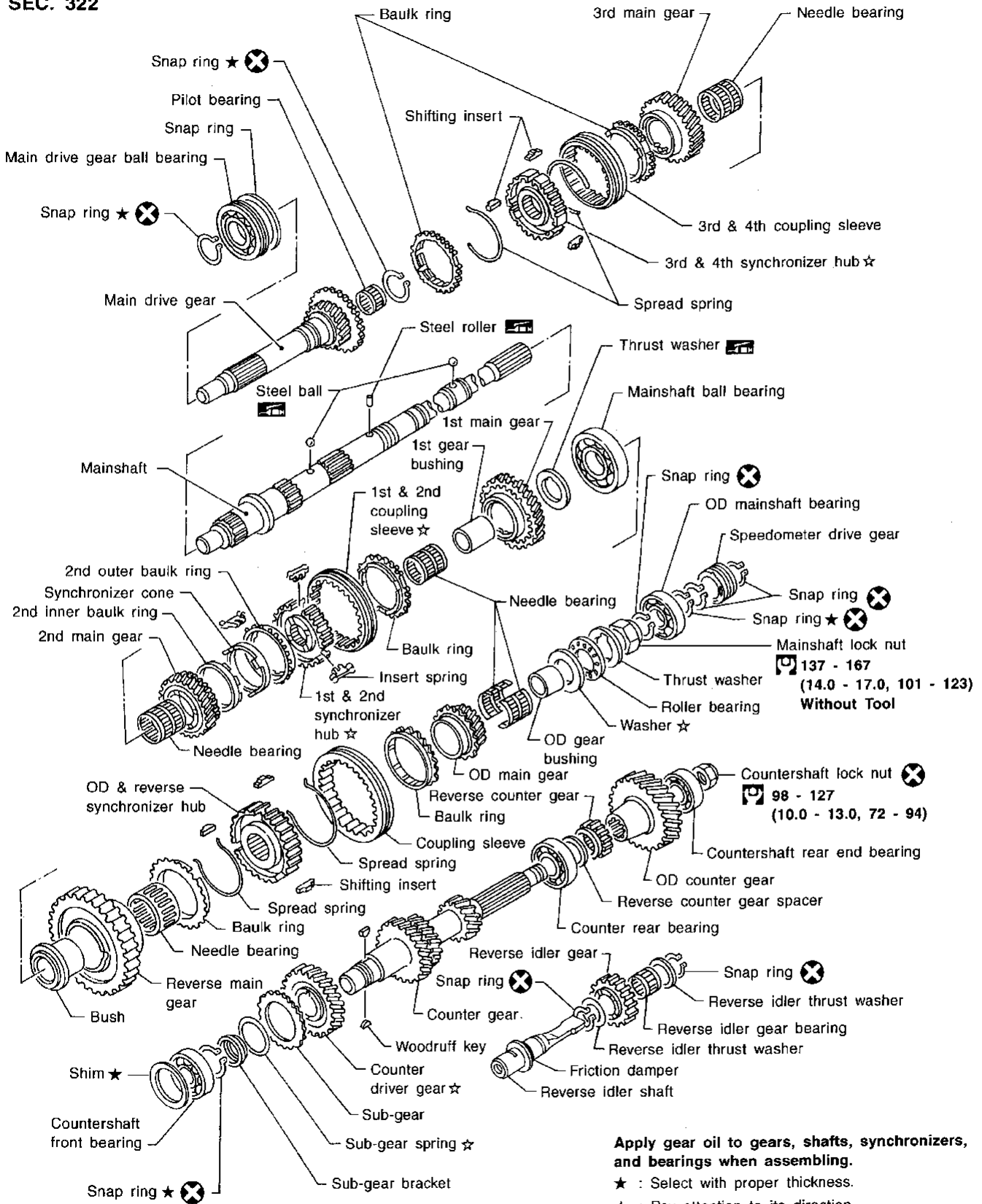

GI
MA
EM
LC
EC
FE
CL
MT
AT
PD
FA
RA
BR
ST
RS
BT
HA
EL
IDX

SMT772CA

MAJOR OVERHAUL

Shift Control Components

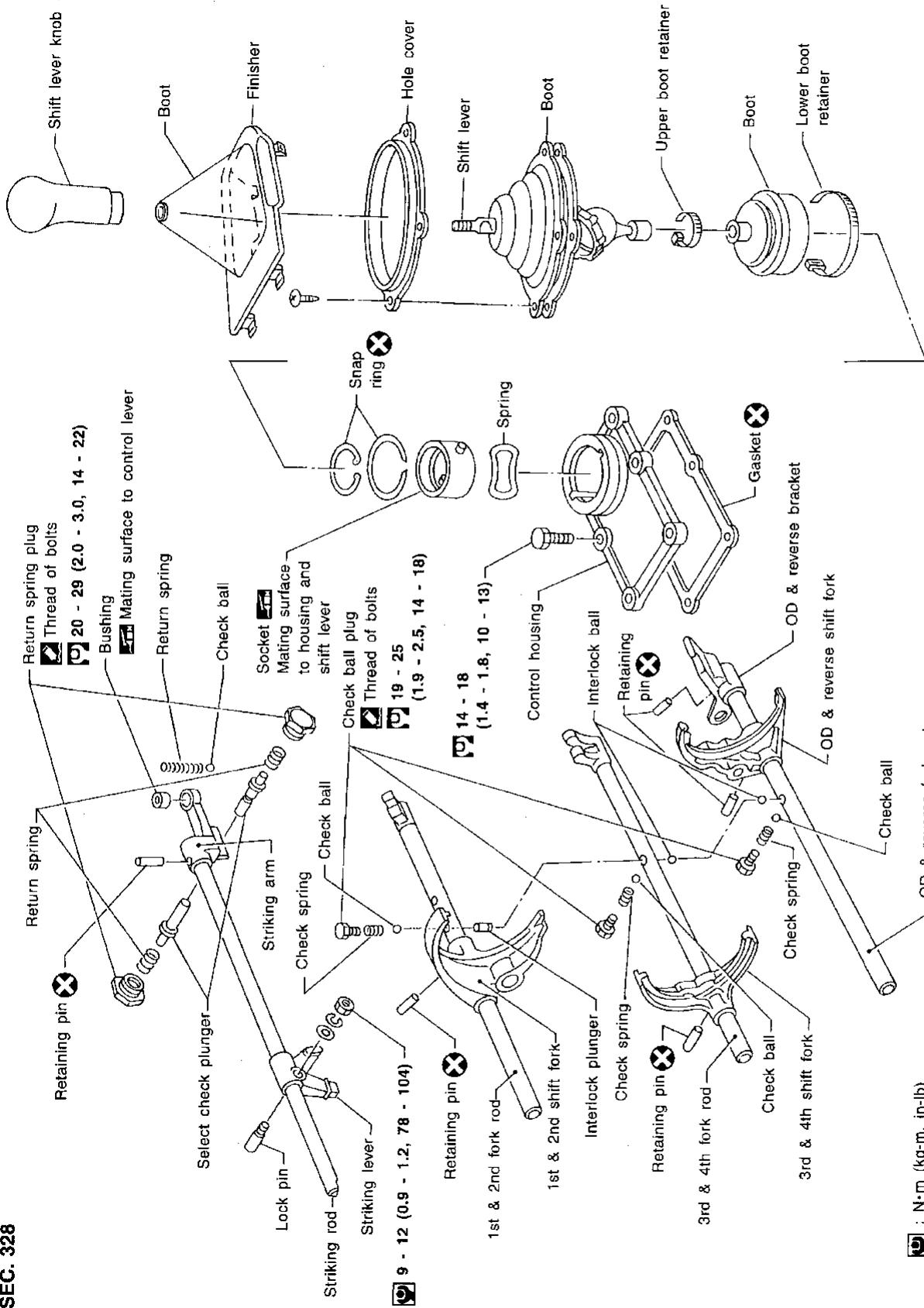

CAUTION:
 To avoid damage when replacing shift lever knob, remove shift lever with knob as an assembly.

: N·m (kg-m, in-lb)

: N·m (kg-m, ft-lb)

: Apply recommended sealant (Nissan genuine part: KP610-00250) or equivalent.

SEC. 328

DISASSEMBLY

Case Components

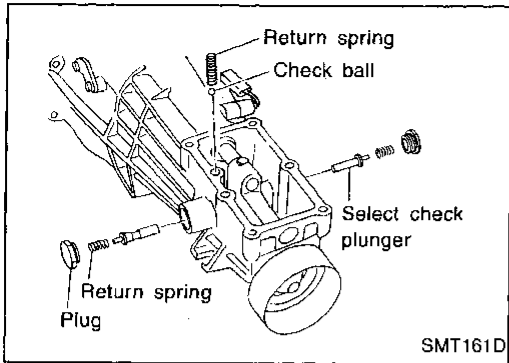

1. Remove rear extension.
 - a. Remove control housing, check ball, return spring plug, select check plunger and return springs.

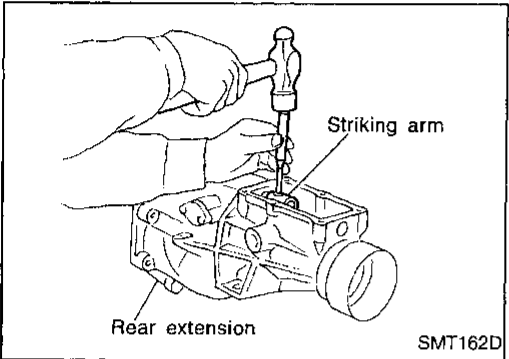

- b. Drive out striking arm retaining pin.
 - c. Remove striking arm from striking rod.

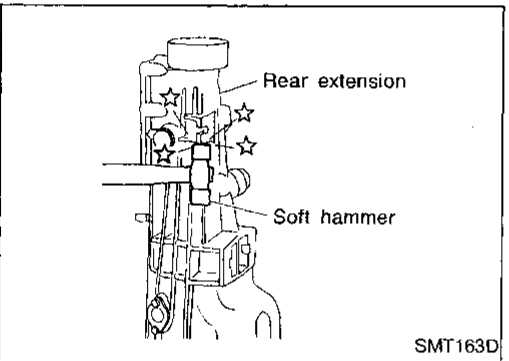

- d. Remove rear extension by lightly tapping it.

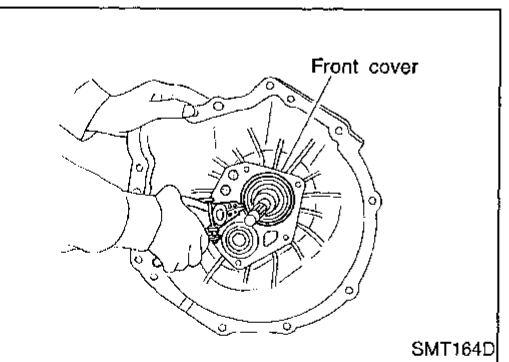

2. Remove front cover, gasket, shim of countershaft front bearing, and snap ring of main drive gear ball bearing.

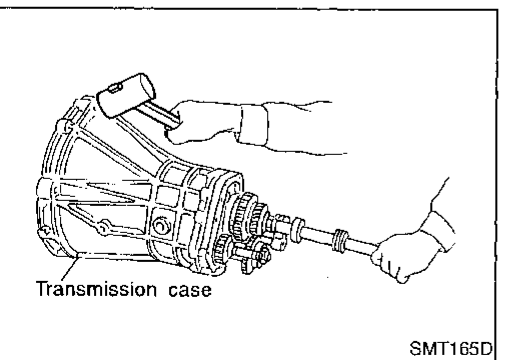

3. Remove transmission case by tapping lightly.

GI

MA

EM

LC

EC

FE

CL

MT

AT

PD

FA

RA

BR

ST

RS

BT

HA

EL

IDX

DISASSEMBLY

Case Components (Cont'd)

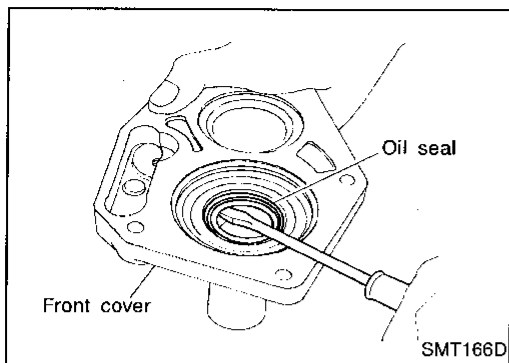

4. Remove front cover oil seal.
- Be careful not to damage front cover mating surface.

Shift Control Components

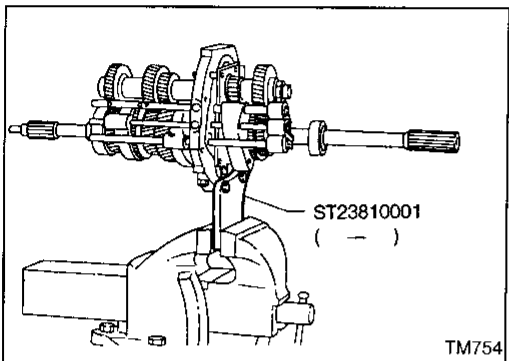

1. Set up Tool on adapter plate.
2. Remove striking rod from adapter plate.
3. Remove check ball plugs, check springs, and check balls.

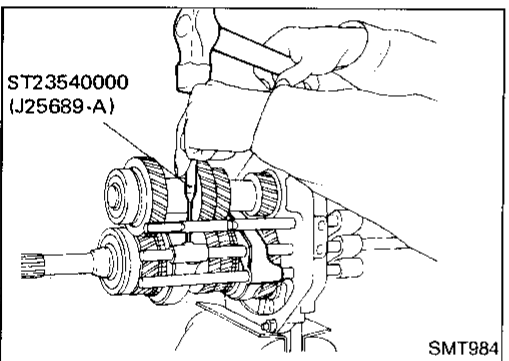

4. Drive out retaining pins. Then drive out fork rods and remove interlock balls.

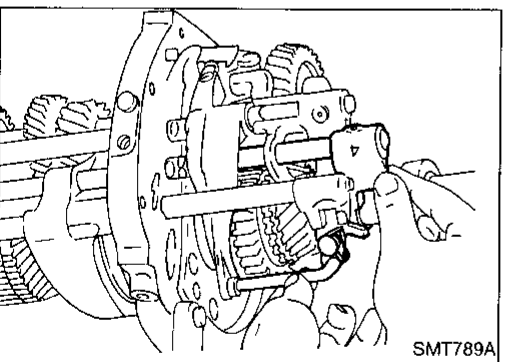

5. Draw out 3rd-4th and OD-reverse fork rods.

Gear Components

1. Before removing gears and shafts, measure each gear end play.

Gear end play:

Refer to SDS, MT-29.

If not within specification, disassemble and check contact surface of gear to hub, washer, bushing, needle bearing and shaft.

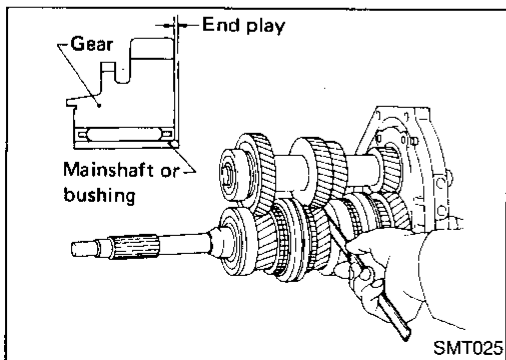

DISASSEMBLY

Gear Components (Cont'd)

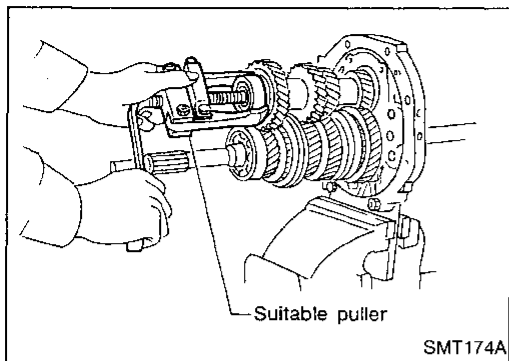

2. Mesh 2nd and reverse gear, then draw out counter front bearing with suitable puller.
3. Remove snap ring and then remove sub-gear bracket, sub-gear spring and sub-gear.

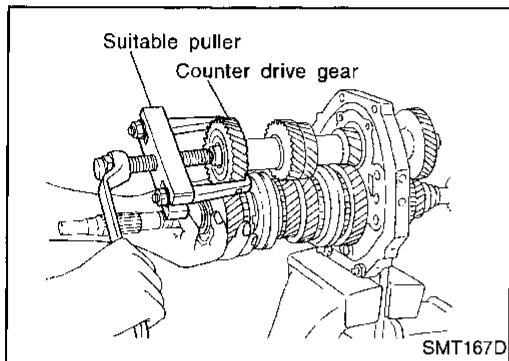

4. Draw out counter drive gear with main drive gear assembly with suitable puller.

- **When drawing out main drive gear assembly, be careful not to drop pilot bearing and baulk ring.**

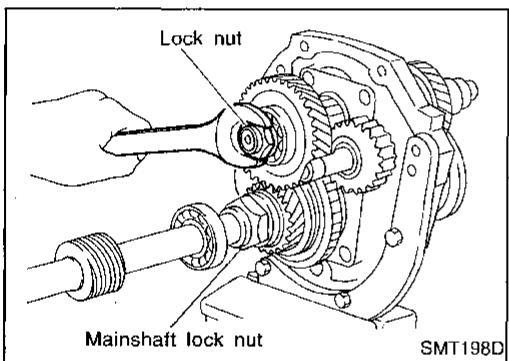

5. Remove rear side components on mainshaft and counter gear.
 - a. Release staking on countershaft nut and mainshaft nut and loosen these nuts.

- **Mainshaft lock nut: Left-hand thread**

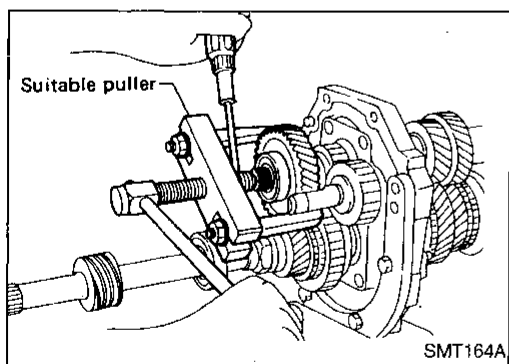

- b. Pull out OD counter gear with bearing with suitable puller.
- c. Draw out reverse counter gear and spacer.
- d. Remove snap rings from reverse idler shaft and draw out reverse idler gear, thrust washers and reverse idler gear bearing.
- e. Remove speedometer drive gear and steel ball.

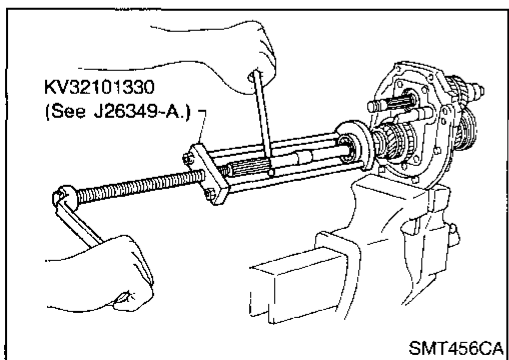

- f. Remove snap ring and pull out OD mainshaft bearing, then remove snap ring.
- g. Remove mainshaft nut.
- h. Remove steel roller and washer.
- i. Remove roller bearing and washer.
- j. Remove OD main gear, needle bearing and baulk ring (OD).
- k. Remove OD coupling sleeve and shifting inserts.

GI

MA

EM

LC

EC

FE

CL

MT

AT

PD

FA

RA

BR

ST

RS

BT

HA

EL

IDX

641

DISASSEMBLY

Gear Components (Cont'd)

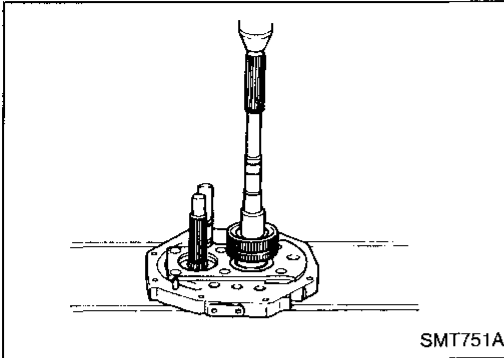

- I. Press out mainshaft and counter gear alternately.
 - Press down mainshaft and counter gear alternately and carefully. Do not allow gears attached to mainshaft and counter gear underneath adapter plate to hit each other.

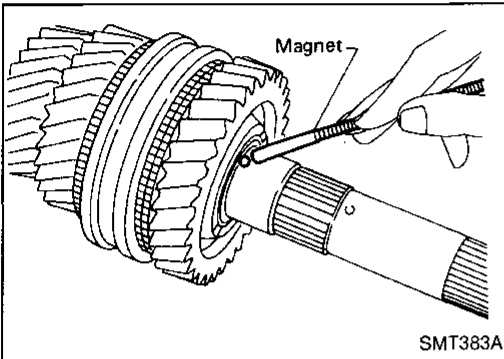

6. Remove front side components on mainshaft.
 - a. Remove 1st gear washer and steel ball.
 - b. Remove 1st main gear and 1st gear needle bearing.
 - Be careful not to lose steel ball.

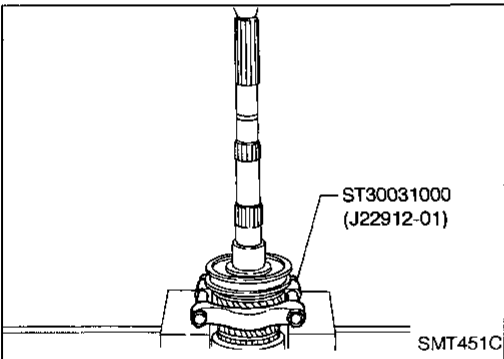

- c. Press out 2nd main gear together with 1st gear bushing and 1st & 2nd synchronizer assembly.
- d. Remove mainshaft front snap ring.

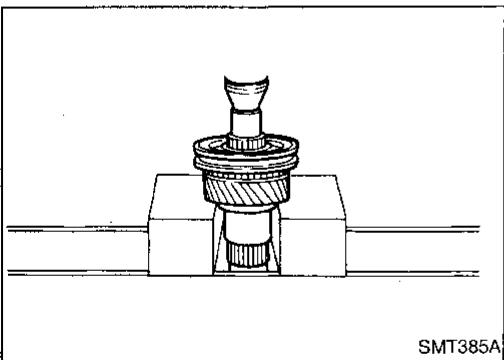

- e. Press out 3rd main gear together with 3rd & 4th synchronizer assembly and 3rd gear needle bearing.

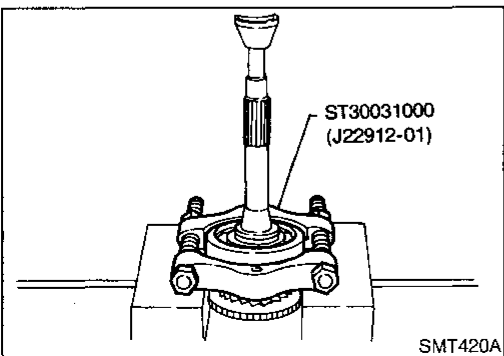

7. Remove main drive gear bearing.
 - a. Remove main drive gear snap ring and spacer.
 - b. Press out main drive gear bearing.

INSPECTION

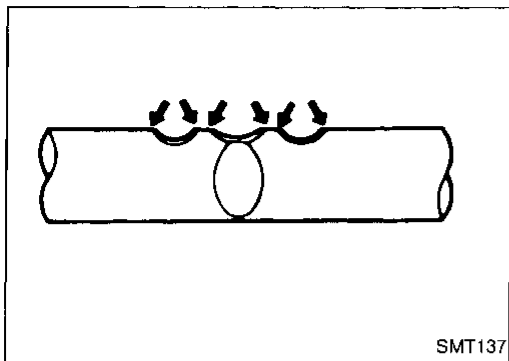

Shift Control Components

- Check contact surface and sliding surface for wear, scratches, projections or other damage.

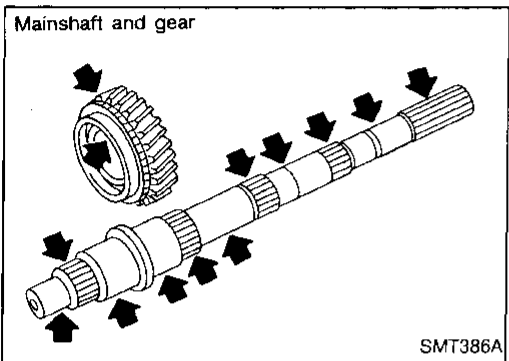

Gear Components

GEAR AND SHAFT

- Check shafts for cracks, wear or bending.
- Check gears for excessive wear, chips or cracks.

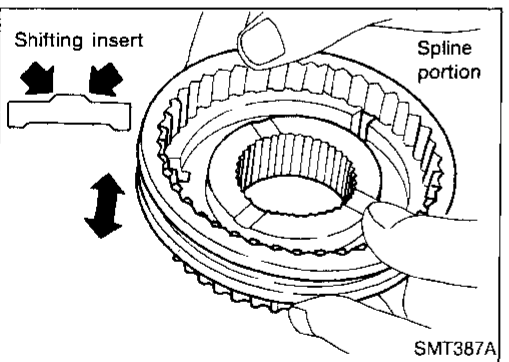
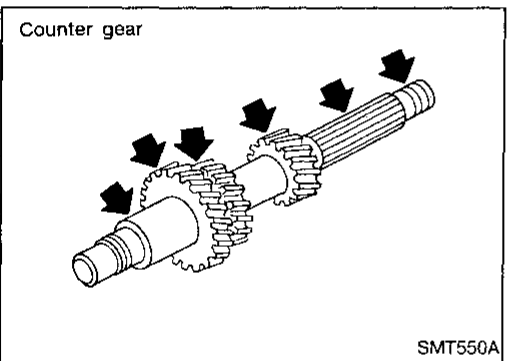

SYNCHRONIZERS

- Check spline portion of coupling sleeves, hubs and gears for wear or cracks.
- Check baulk rings for cracks or deformation.
- Check shifting inserts for wear or deformation.
- Check spread spring for deformation.

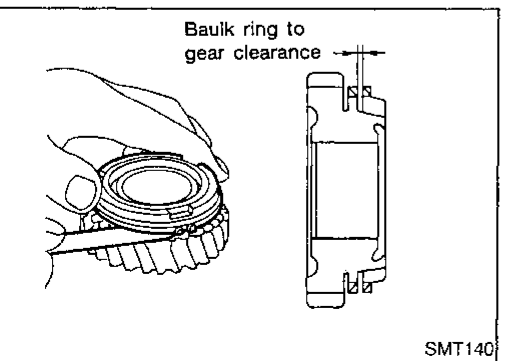

- Measure clearance between baulk ring and gear.

Clearance between baulk ring and gear
(1st, 3rd, main drive, OD and reverse baulk ring):
Refer to SDS, MT-30.

If the clearance is smaller than the wear limit, replace baulk ring.

GI

MA

EM

LC

EC

FE

CL

MT

AT

PD

FA

RA

BR

ST

RS

BT

HA

EL

IDX

INSPECTION

Gear Components (Cont'd)

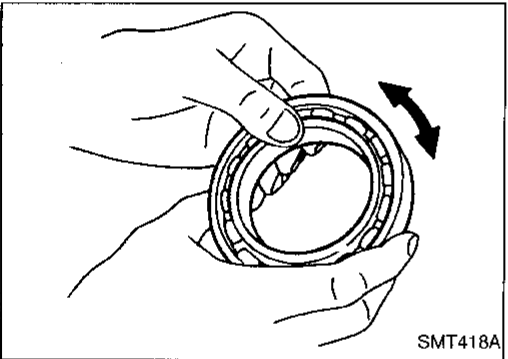
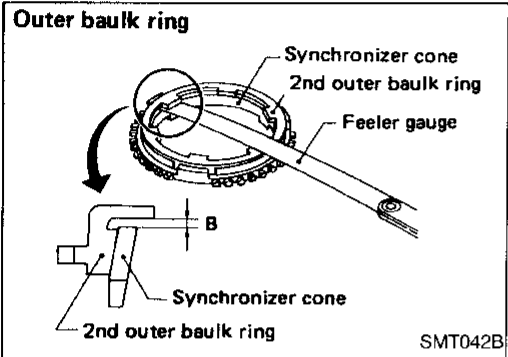
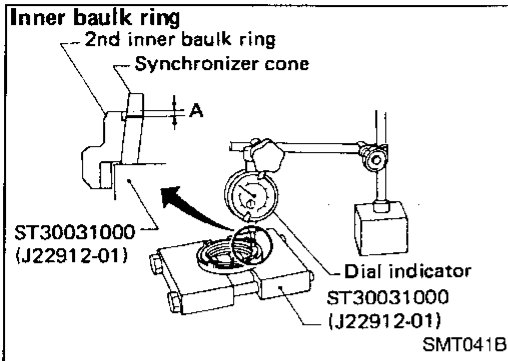

- Measure wear of 2nd baulk ring.
 - a. Place baulk rings in position on synchronizer cone.
 - b. While holding baulk rings against synchronizer cone as far as it will go, measure dimensions "A" and "B".

Standard:

Inner-A 0.7 - 0.9 mm (0.028 - 0.035 in)

Outer-B 0.6 - 1.1 mm (0.024 - 0.043 in)

Wear limit:

0.2 mm (0.008 in)

- If dimension "A" or "B" is smaller than the wear limit, replace outer baulk ring, inner baulk ring and synchronizer cone as a set.

BEARINGS

- Make sure bearings roll freely and are free from noise, crack, pitting or wear.

ASSEMBLY

Gear Components

1. Install bearings into case components.

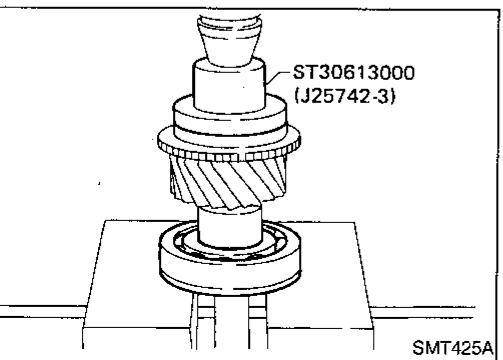
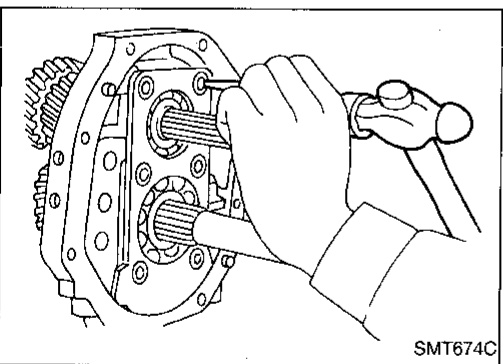
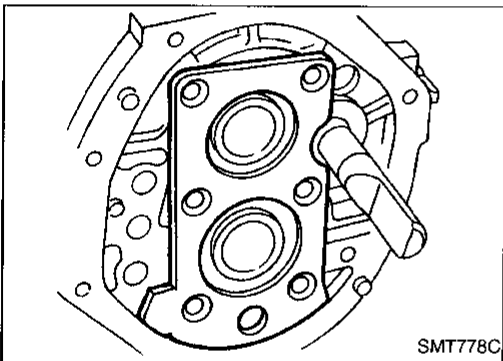
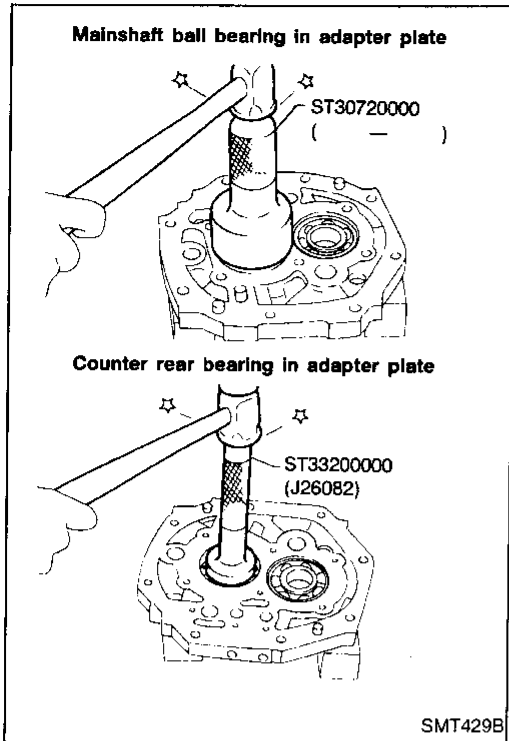

2. Assemble adapter plate parts.
 - Install bearing retainer.
 - a. Insert reverse shaft, then install bearing retainer.
 - b. Tighten each screw, then stake each at two points.
3. Install main drive gear bearing.
 - a. Press main drive gear bearing.
 - b. Install main drive gear spacer.

GI

MA

EM

LC

EC

FE

CL

MT

AT

PD

FA

RA

BR

ST

RS

BT

HA

EL

IDX

ASSEMBLY

Gear Components (Cont'd)

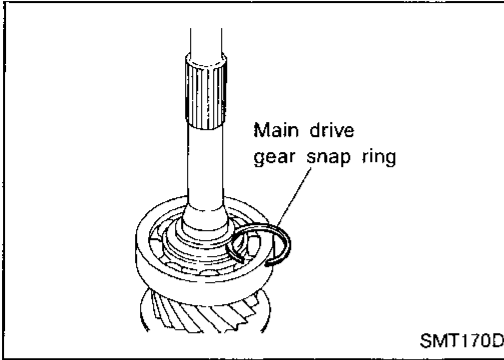

- c. Select proper main drive gear snap ring to minimize clearance of groove and install it.

Allowable clearance of groove:
0 - 0.13 mm (0 - 0.0051 in)

Main drive gear bearing snap ring:
Refer to SDS, MT-30.

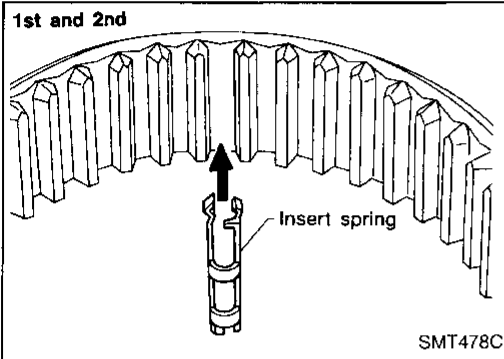

- 4. Assemble synchronizers.
 - 1st & 2nd synchronizer

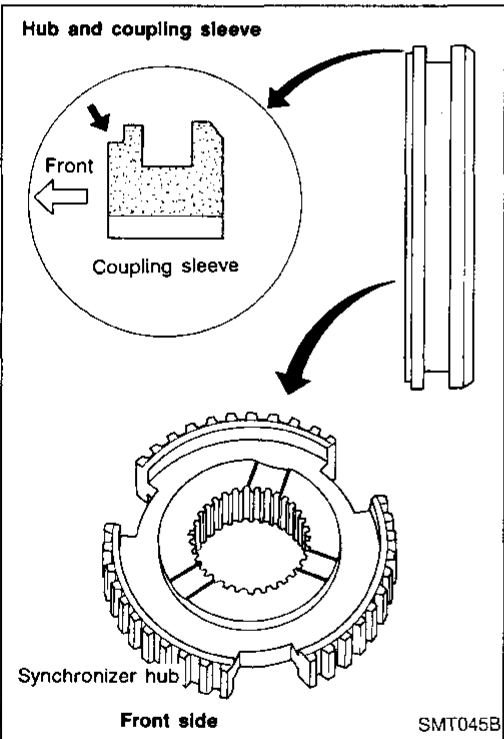

- Check coupling sleeve and synchronizer hub orientation.

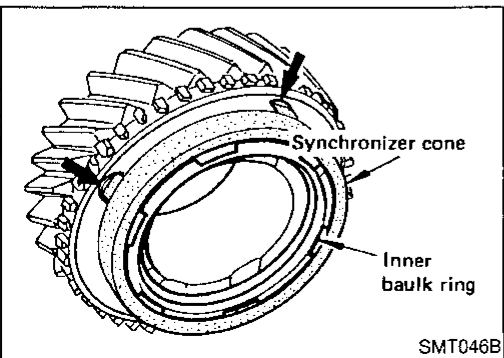

ASSEMBLY

Gear Components (Cont'd)

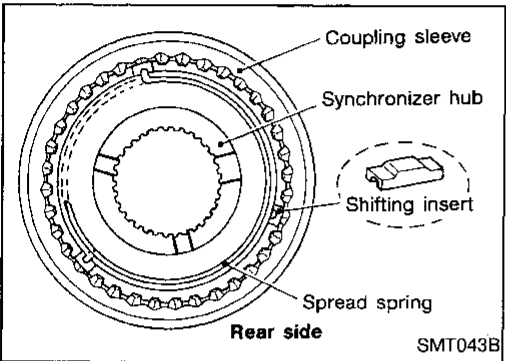
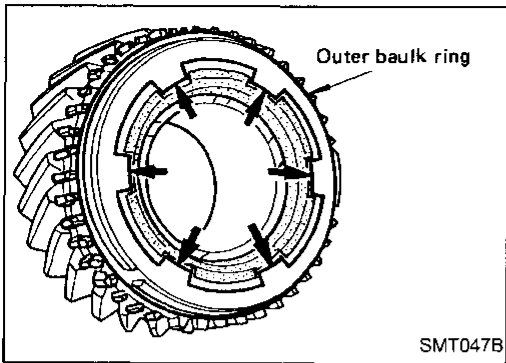

- 3rd & 4th synchronizer

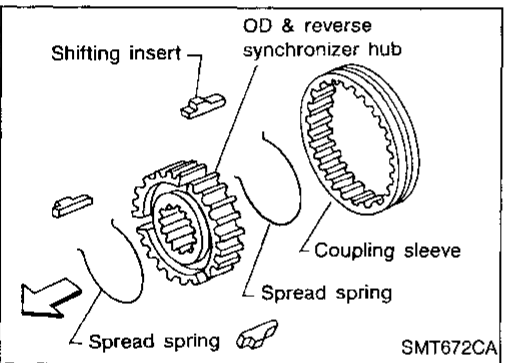

- OD & reverse synchronizer

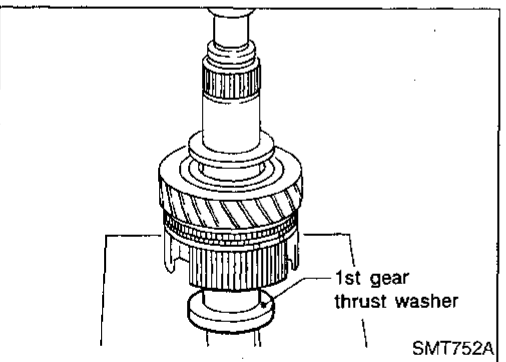

5. Install front side components on main shaft.
 - a. Assemble 2nd main gear, needle bearing and 1st & 2nd synchronizer assembly. Then press 1st gear bushing on main shaft.
 - b. Install 1st main gear.

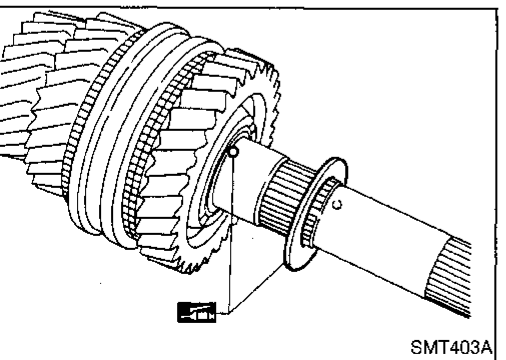

- c. Install steel ball and 1st gear washer.
 - **Apply multi-purpose grease to steel ball and 1st gear washer before installing.**

GI

MA

EM

LC

EC

FE

CL

MT

AT

PD

FA

RA

BR

ST

RS

BT

HA

EL

IDX

647

ASSEMBLY

Gear Components (Cont'd)

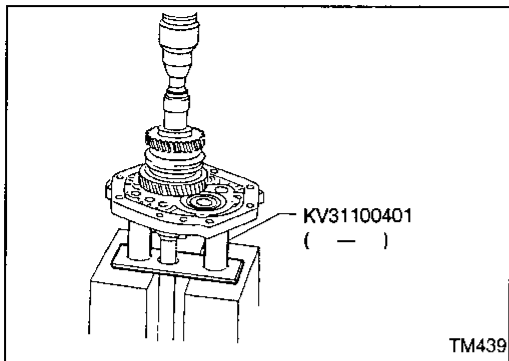

6. Install mainshaft and counter gear on adapter plate and main drive gear on mainshaft.
 - a. Press mainshaft assembly to adapter plate with Tool.

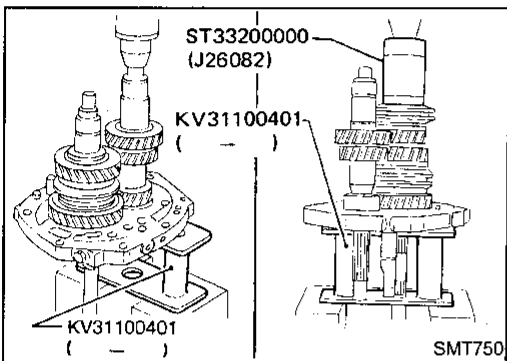

- b. Press counter gear into adapter plate with Tool.
 - c. Install 3rd main gear and then press 3rd & 4th synchronizer assembly.

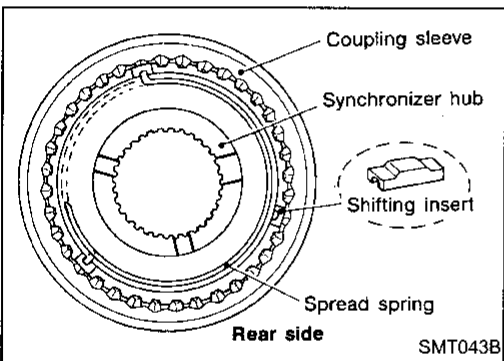

- Pay attention to direction of 3rd & 4th synchronizer.

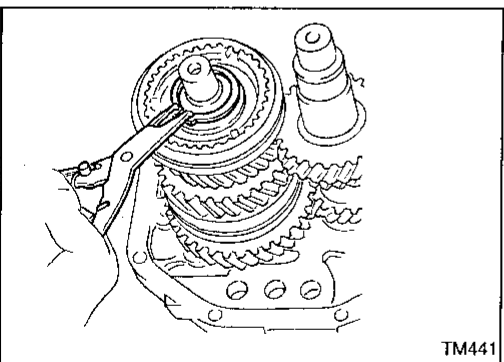

- d. Install thrust washer on mainshaft and secure it with mainshaft front snap ring. Select proper snap ring to minimize clearance of groove in mainshaft.

Allowable clearance of groove:

0 - 0.18 mm (0 - 0.0071 in)

Mainshaft front snap ring:

Refer to SDS, MT-30.

- e. Apply gear oil to mainshaft pilot bearing and install it on mainshaft.

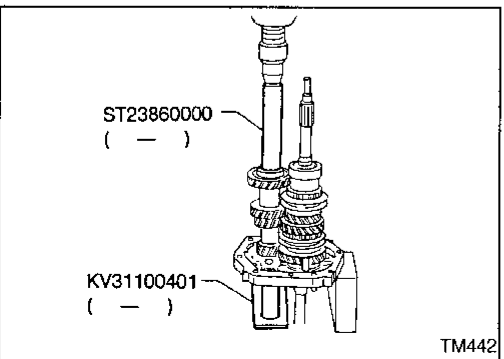

- f. Press counter drive gear with main drive gear with Tool.

ASSEMBLY

Gear Components (Cont'd)

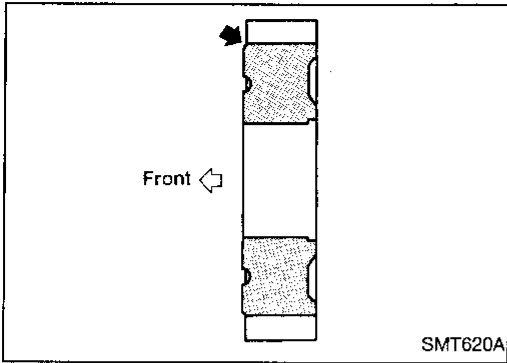

- Pay attention to direction of counter drive gear.

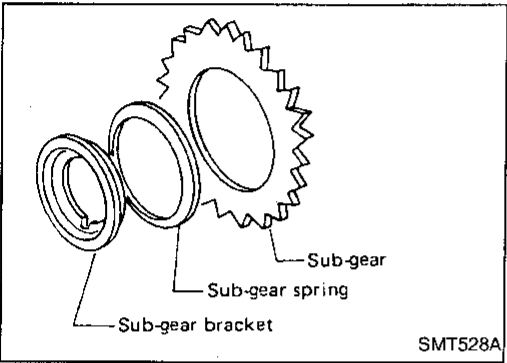

- g. Install sub-gear components.
 (1) Install sub-gear and sub-gear bracket on counter drive gear. Then select proper snap ring to minimize clearance of groove in counter gear.

Allowable clearance of groove:
 0 - 0.13 mm (0 - 0.0051 in)

Counter drive gear snap ring:
 Refer to SDS, MT-30.

- (2) Remove snap ring, sub-gear bracket and sub-gear from counter gear.
 (3) Reinstall sub-gear, sub-gear spring and sub-gear bracket.

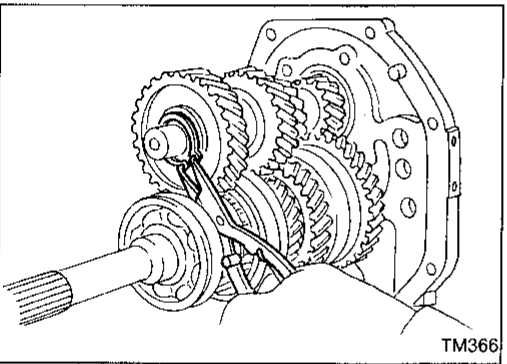

- h. Install selected counter drive gear snap ring.

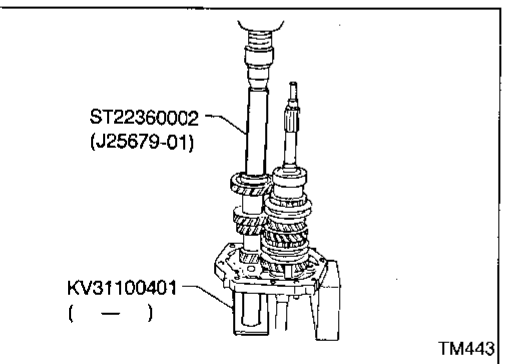

- i. Press counter gear front bearing onto counter gear.

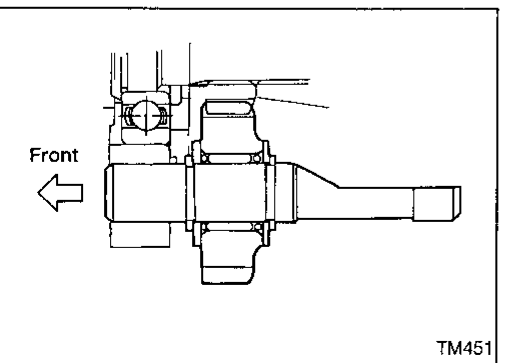

7. Install rear side components on mainshaft and counter gear.
 a. Install reverse idler gear to reverse idler shaft with spacers, snap rings and needle bearing.

GI

MA

EM

LC

EC

FE

CL

MT

AT

PD

FA

RA

BR

ST

RS

BT

HA

EL

IDX

ASSEMBLY

Gear Components (Cont'd)

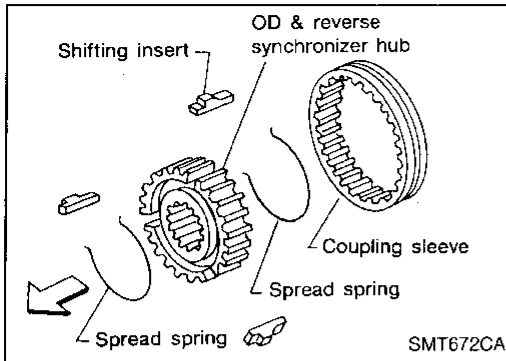

b. Install insert retainer and OD & reverse synchronizer to mainshaft.

- Pay attention to direction of hub.

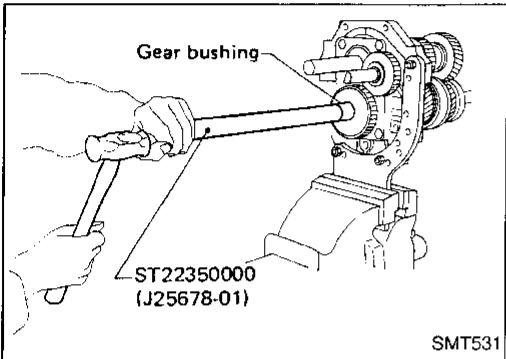

c. Install OD gear bushing with Tool.

d. Install OD main gear and needle bearing.

e. Install spacer, reverse counter gear and OD counter gear.

- OD main gear and OD counter gear should be handled as a matched set.

f. Install washer, roller bearing, steel roller and thrust washer.

g. Tighten mainshaft lock nut temporarily.

- Always use new lock nut.

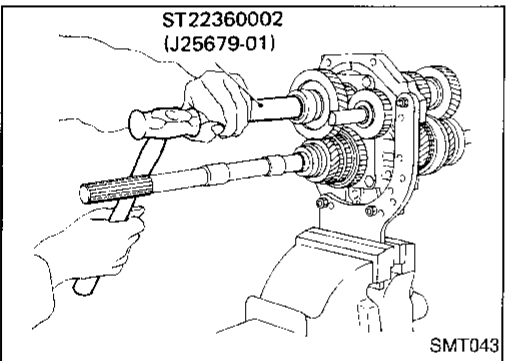

h. Install countershaft rear end bearing with Tool.

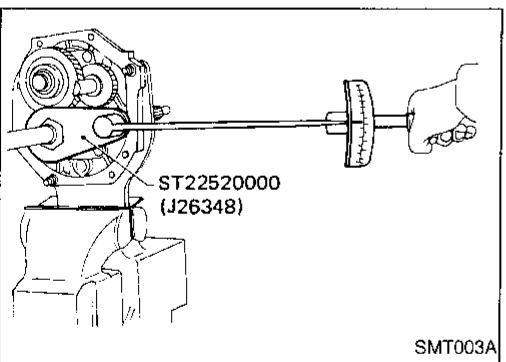

8. Mesh 2nd and reverse gears, then tighten mainshaft lock nut with Tool.

ASSEMBLY

Gear Components (Cont'd)

- Refer to the figure at the left to determine the converted torque value.

Reference: Formula to convert torque wrench indication to the true torque value:

$$T = \frac{0.1 \text{ m (0.33 ft)} + L}{L} \times C$$

If the specified torque is T kg-m (ft-lb), the torque wrench scale indication C is determined using the following formula.

$$C = \frac{T \times L}{0.1 \text{ m (0.33 ft)} + L}$$

- Tighten counter gear lock nut.

- Always use new lock nut.**

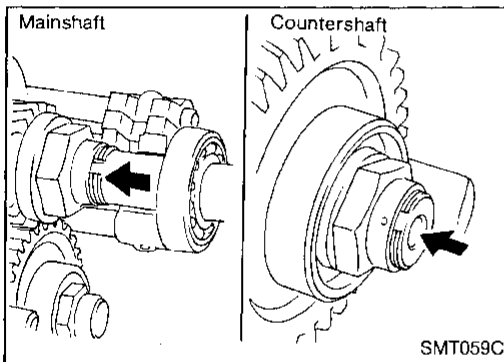
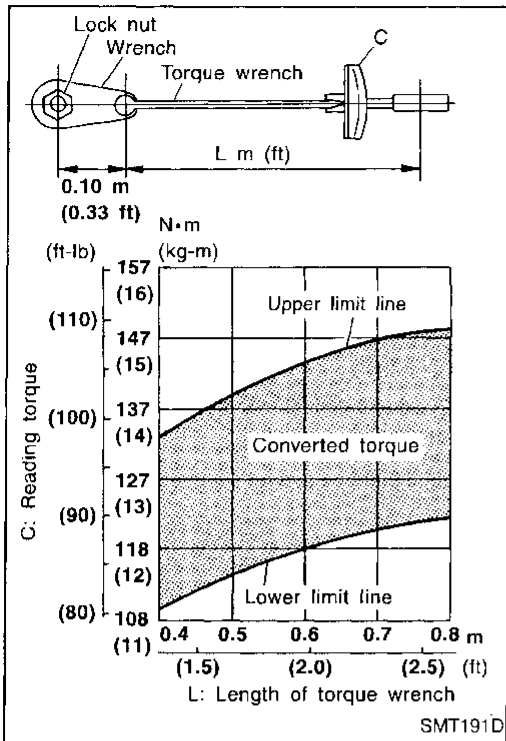

- Stake mainshaft lock nut and countershaft lock nut with a punch.

- Measure gear end play. For the description, refer to DISASSEMBLY for Gear Components, MT-14.

- Install snap ring and OD mainshaft bearing, then snap ring.

Allowable clearance:

0 - 0.14 mm (0 - 0.0055 in)

OD mainshaft snap ring:

Refer to SDS, MT-30.

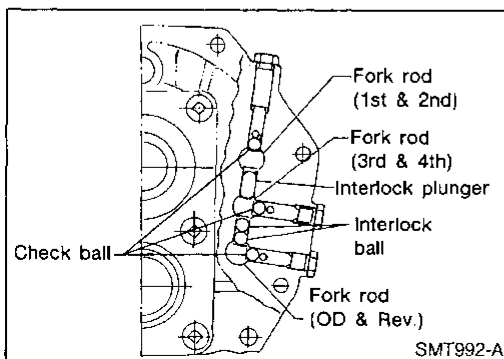

Shift Control Components

- Install fork rods, interlock plunger, interlock balls and check balls.

ASSEMBLY

Shift Control Components (Cont'd)

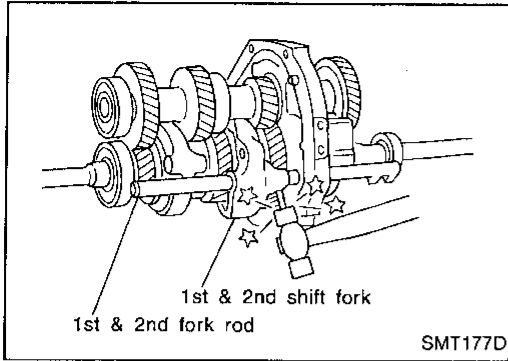

a. Install 1st-2nd shift fork, then drive in retaining pin.

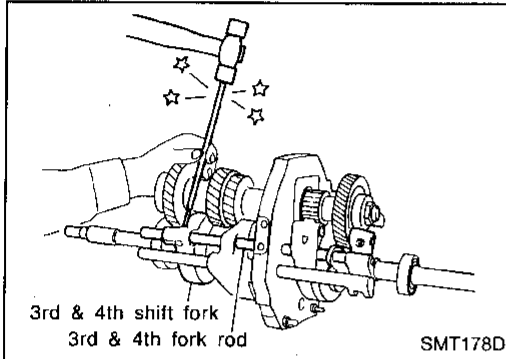

b. Install 3rd-4th shift fork, then drive in retaining pin.

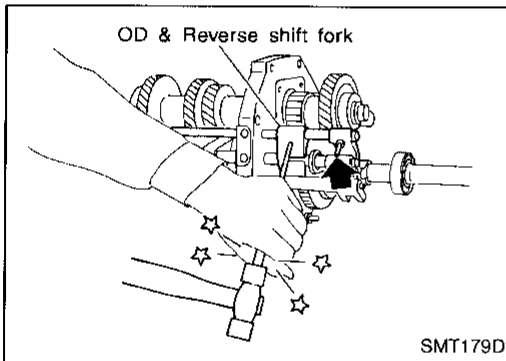

c. Install OD-reverse shift fork or reverse shift fork, then drive in retaining pin.

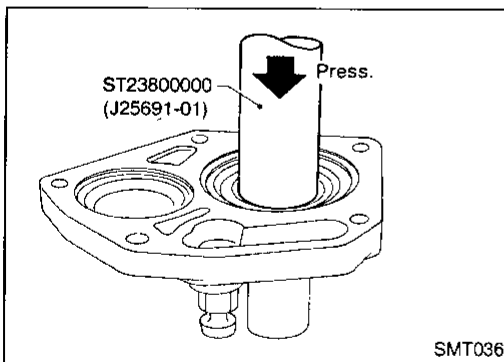

Case Components

1. Install front cover oil seal.

- Apply multi-purpose grease to seal lip of oil seal before installing.

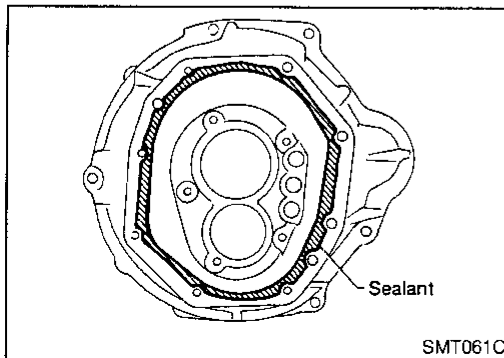

2. Apply sealant to mating surface of transmission case.

ASSEMBLY

Case Components (Cont'd)

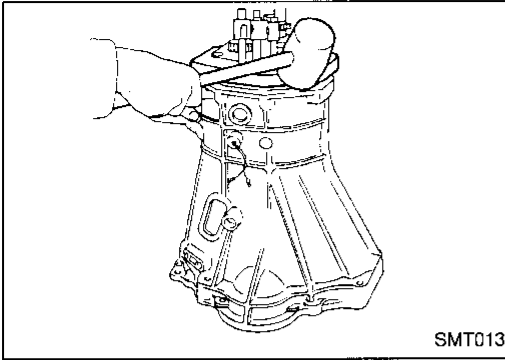

3. Install gear assembly with adapter plate on transmission case by lightly tapping with a soft hammer.

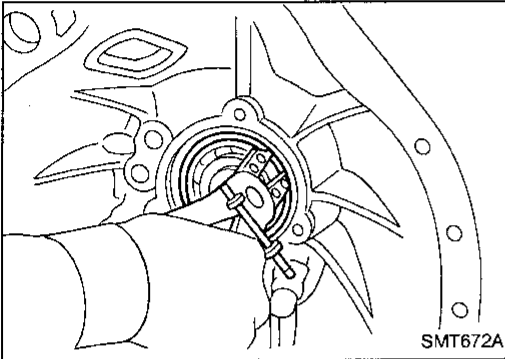

4. Install snap ring of main drive bearing.

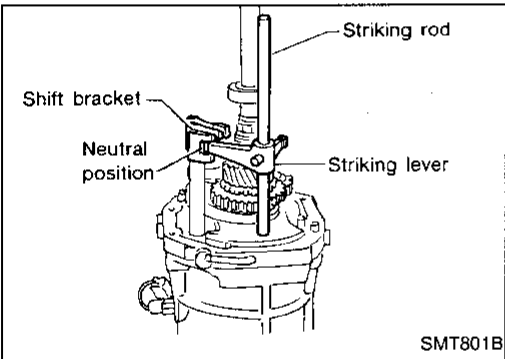

5. Set 1st & 2nd, 3rd & 4th and 5th & reverse shift forks in neutral position.
6. Install striking rod onto adapter plate while aligning striking lever with shift brackets.

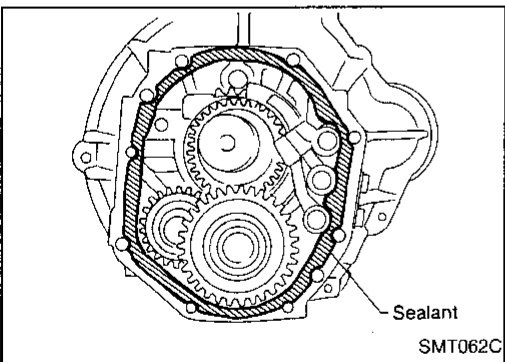

7. Apply sealant to mating surface of adapter plate.
8. Install rear extension while inserting striking arm into striking rod.

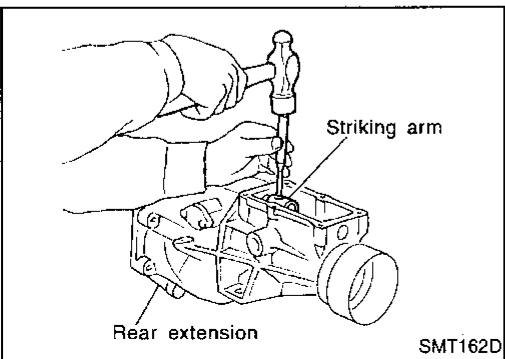

9. Install striking arm retaining pin.

GI

MA

EM

LC

EC

FE

CL

MT

AT

PD

FA

RA

BR

ST

RS

BT

HA

EL

IDX

ASSEMBLY

Case Components (Cont'd)

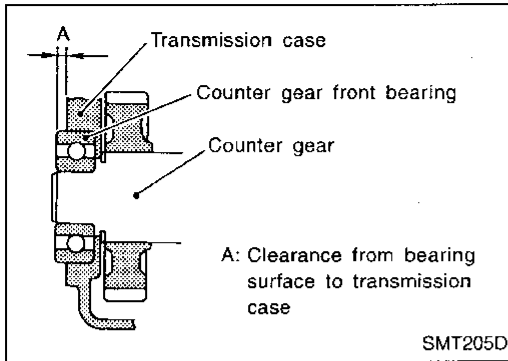

10. Select counter front bearing shim.

Counter front bearing shim:

Refer to SDS, MT-30.

11. Install gasket and front cover.

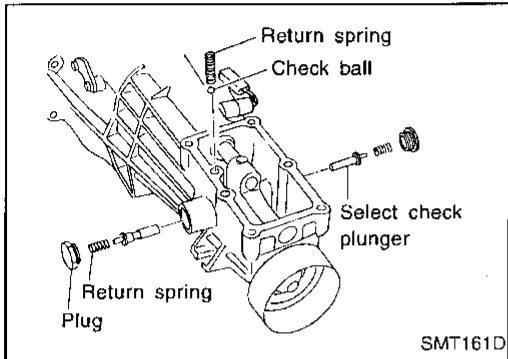

12. Install return spring plugs, check ball, return springs and select check plunger.

13. Install control housing and gasket.

SERVICE DATA AND SPECIFICATIONS (SDS)

General Specifications

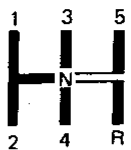
Transmission model		FS5W71C		
Number of speeds		5		
Shift pattern				GI MA
Synchronmesh type		Warner		EM
Gear ratio	1st		3.321	
	2nd		1.902	LC
	3rd		1.308	
	4th		1.000	EC
	OD		0.759	
	Reverse		3.382	
	Number of teeth	Mainshaft	Drive	22
1st			33	
2nd			27	CL
3rd			26	
OD			21	MT
Reverse			36	
Countershaft			Drive	31
		1st	14	
		2nd	20	PD
		3rd	28	
		OD	39	FA
		Reverse	15	
		Reverse idler gear		21
Oil capacity		ℓ (US pt, Imp pt)	2.5 (5-1/4, 4-3/8)	RA
Remarks	Sub-gear		○	
	Reverse synchronizer		○	
	Double baulk ring type synchronizer		2nd synchronizer	BR

Inspection and Adjustment

GEAR END PLAY

Unit: mm (in)

Gear	End play
1st gear	0.31 - 0.41 (0.0122 - 0.0161)
2nd gear	0.11 - 0.21 (0.0043 - 0.0083)
3rd gear	0.11 - 0.21 (0.0043 - 0.0083)
OD gear	0.24 - 0.41 (0.0094 - 0.0161)

SERVICE DATA AND SPECIFICATIONS (SDS)

Inspection and Adjustment (Cont'd)

CLEARANCE BETWEEN BAULK RING AND GEAR

1st, 3rd, main drive, OD and reverse baulk ring

Unit: mm (in)

	Standard	Wear limit
1st	1.2 - 1.6 (0.047 - 0.063)	0.8 (0.031)
3rd and main drive	1.2 - 1.6 (0.047 - 0.063)	
OD	1.2 - 1.6 (0.047 - 0.063)	
Reverse	1.10 - 1.55 (0.0433 - 0.0610)	0.7 (0.028)

2nd baulk ring

Unit: mm (in)

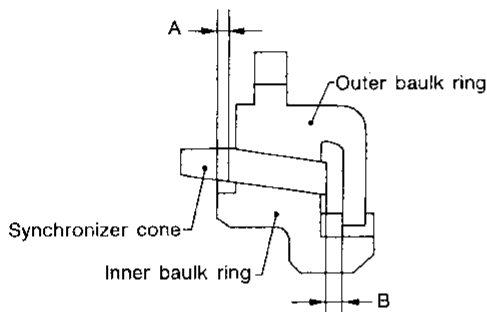

SMT733C

Dimension	Standard	Wear limit
A	0.7 - 0.9 (0.028 - 0.035)	0.2 (0.008)
B	0.6 - 1.1 (0.024 - 0.043)	

AVAILABLE SNAP RINGS

Main drive gear bearing

Unit: mm (in)

Allowable clearance	0 - 0.13 (0 - 0.0051)
Thickness	Part number
1.87 (0.0736)	32204-78001
1.94 (0.0764)	32204-78002
2.01 (0.0791)	32204-78003

Mainshaft (front)

Unit: mm (in)

Allowable clearance	0 - 0.18 (0 - 0.0071)
Thickness	Part number
2.4 (0.094)	32263-V5200
2.5 (0.098)	32263-V5201

OD mainshaft bearing

Unit: mm (in)

Allowable clearance	0 - 0.14 (0 - 0.0055)
Thickness	Part number
1.1 (0.043)	32228-20100
1.2 (0.047)	32228-20101
1.3 (0.051)	32228-20102
1.4 (0.055)	32228-20103

Counter drive gear

Unit: mm (in)

Allowable clearance	0 - 0.13 (0 - 0.0051)
Thickness	Part number
1.4 (0.055)	32215-E9000
1.5 (0.059)	32215-E9001
1.6 (0.063)	32215-E9002

AVAILABLE SHIMS

Counter front bearing

Unit: mm (in)

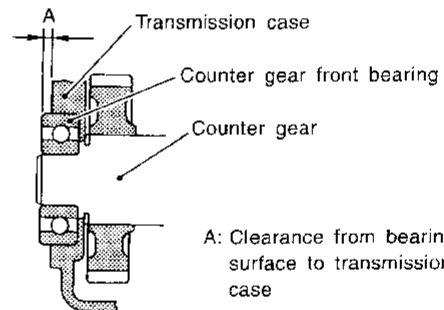

A: Clearance from bearing surface to transmission case

SMT205D

Allowable clearance	0 - 0.16 (0 - 0.0063)	
"A"	Thickness of shim	Part number
4.52 - 4.71 (0.1780 - 0.1854)	Not necessary	
4.42 - 4.51 (0.1740 - 0.1776)	0.1 (0.004)	32218-V5000
4.32 - 4.41 (0.1701 - 0.1736)	0.2 (0.008)	32218-V5001
4.22 - 4.31 (0.1661 - 0.1697)	0.3 (0.012)	32218-V5002
4.12 - 4.21 (0.1622 - 0.1657)	0.4 (0.016)	32218-V5003
4.02 - 4.11 (0.1583 - 0.1618)	0.5 (0.020)	32218-V5004
3.92 - 4.01 (0.1543 - 0.1579)	0.6 (0.024)	32218-V5005